



## Lifting Columns

Self Supporting, Compact and Versatile Linear Motion for  
Quicker Throughput, Minimal Downtime and No Maintenance



## Meet the Thomson Lifting Column Product Family

Thomson lifting columns are self-supporting, height-adjustable lifting solutions in a compact, pre-aligned package and are perfect for medical and ergonomic applications requiring telescopic motion. Simple, one-step installation requires minimal downtime, and maintenance-free operation ensures worry-free functionality.

These columns are designed for smooth, quiet and fast operation and offer an excellent extension to retraction ratio resulting in the maximum range of motion in a minimal footprint.

Thomson lifting columns are designed to be flexible linear motion solutions based on anodized extruded aluminum profiles which slide into each other. A high moment load capacity, large holding-capacity-to-frame-size ratio and the ability to use a single unit for a center load or multiple units linked together allow for numerous design configurations.

Thomson lifting columns also can be customized for more specific requirements. The result is a self-supporting, compact and versatile lifting solution.

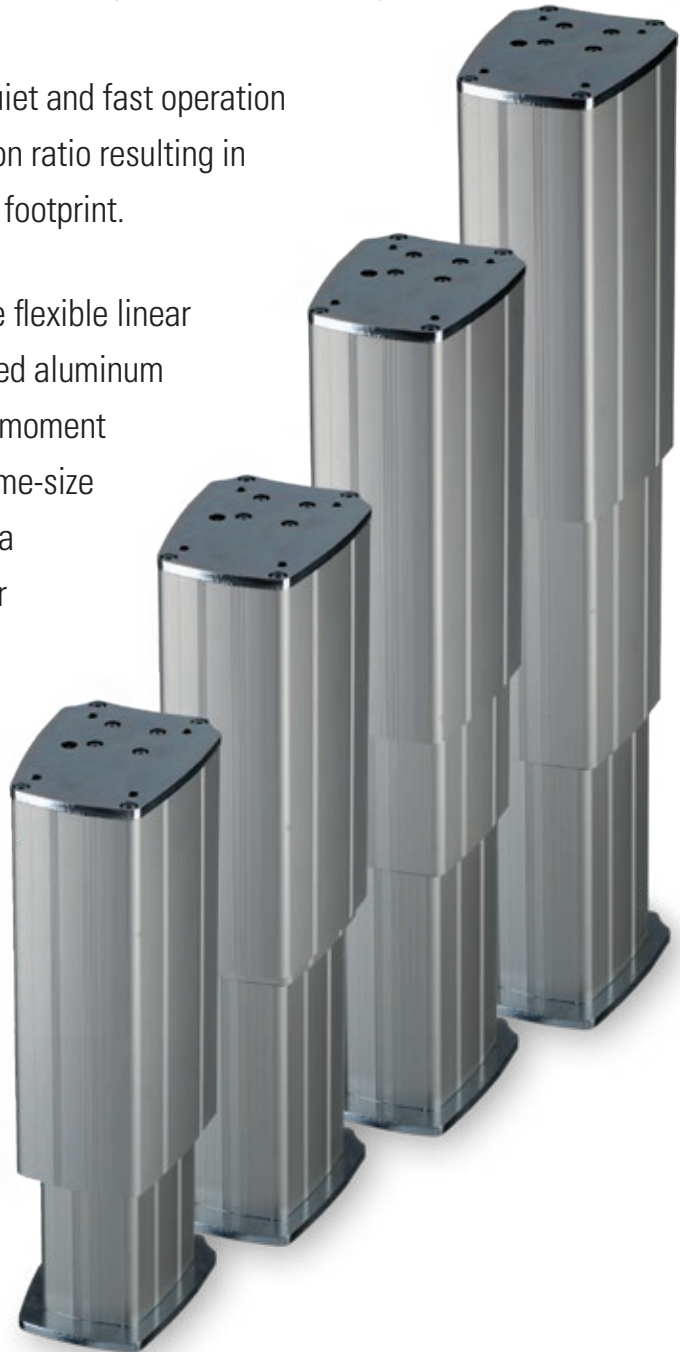

## Features and Benefits

Two different lifting column modules are available from Thomson, all sharing the same basic design and functionality. All models feature easy installation, maintenance-free operation and a high moment load capacity. Though each model has its own unique advantages, the basic features and benefits are the same.

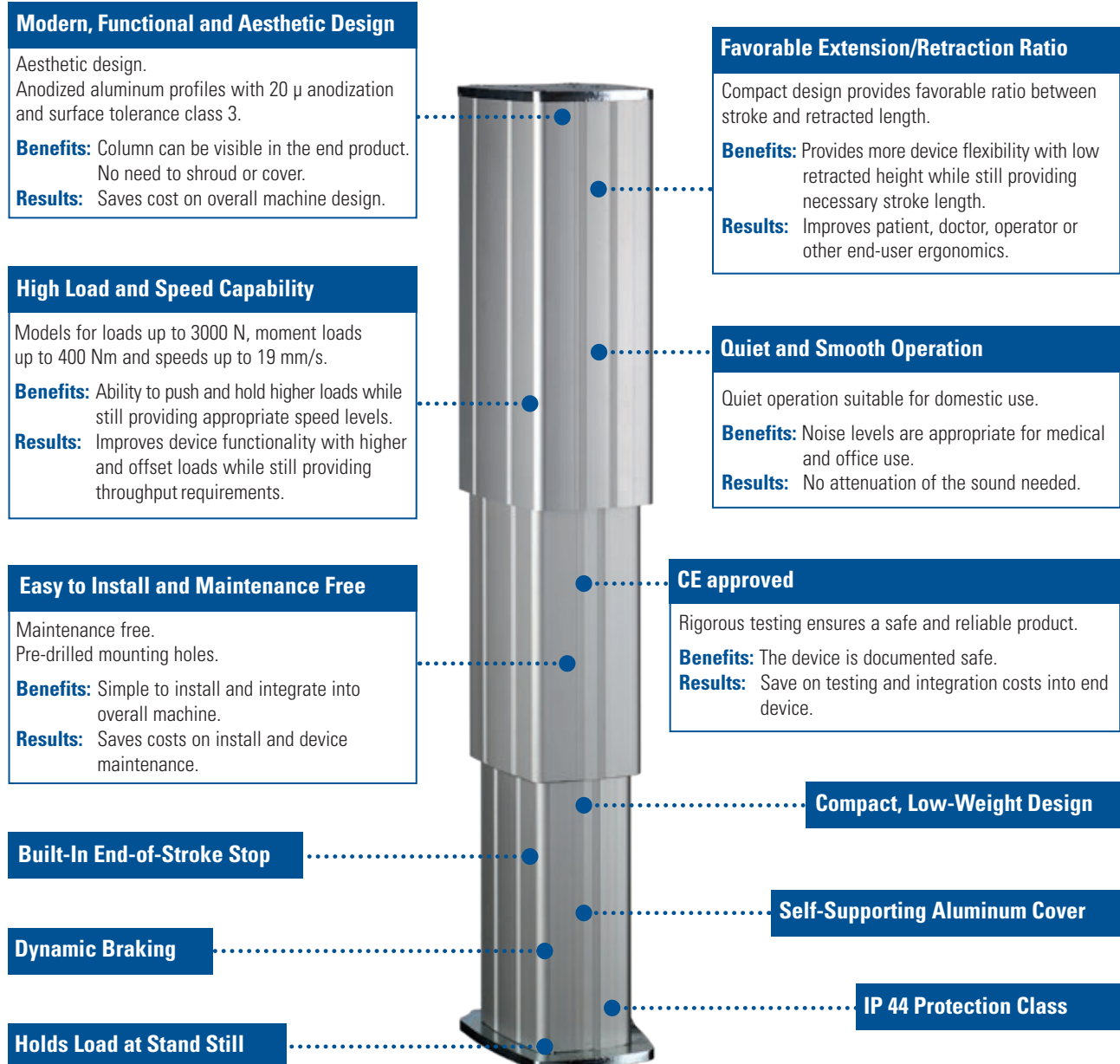

### Common Thomson Lifting Columns Features









## Model Comparison

The Thomson lifting column product family has two different models that are all made of self-supporting, extruded aluminum profiles that are easy to install and require no additional cover for protection. The type of model that is most appropriate depends on the balance that is needed among extension-to-retraction ratio, load capacity, speed and cost.

Model Comparison		
	LC2000	LC3000
Model		
Description	Three-piece extrusion with 2000 N loading capacity and a telescoping leadscrew mechanism to provide an ideal extension-to-retraction ratio.	Three-piece extrusion with ball screw drive mechanism to allow for 3000 N loading capacity and high moment loading.
Screw type	Telescopic lead screw	Ball screw
Weight	Good	Good
Quiet operation	Good	Good
Extension/retraction ratio	Best	Better
Minimum retracted length	Best	Better
Load capacity	Better	Best
Load torque capacity	Good	Best
Duty cycle	Best	Good
Speed	Best	Good
Mid-stroke overload protection	Available with use of DCG Control	Available with use of DCG Control

## Applications

Thomson lifting columns feature easy installation, maintenance-free operation, high moment load capacity and extension-to-retraction ratio, making them especially suited for medical and ergonomic applications. The versatility, flexibility and customizability of these lifting columns make them ideal for numerous applications within these categories.

Medical Applications		Ergonomic Automation Solutions	
Hospital Equipment	Accessibility Equipment	Furniture	Adjustable Chairs
 <ul style="list-style-type: none"> <li>• X-ray machines</li> <li>• Operating/examination tables</li> <li>• Hospital beds and patient lifts</li> </ul>	 <ul style="list-style-type: none"> <li>• Wheel chair lifts</li> <li>• Lifting aids</li> <li>• Handicap adaptation of vehicles</li> </ul>	 <ul style="list-style-type: none"> <li>• Desks and workbenches</li> <li>• Tables</li> <li>• Beds</li> </ul>	 <ul style="list-style-type: none"> <li>• Dental chairs</li> <li>• Barber chairs</li> <li>• Makeup chairs</li> </ul>
<p>Thomson lifting columns provide simple and effective solutions for medical lifting applications such as medical tables, wheelchairs, lifts, patient beds and similar applications.</p>		<p>Easily install a low-cost ergonomic solution to increase operator comfort and productivity in numerous office scenarios such as adjustable tables, desks, carts, workstations and more.</p>	
<p>Simple, all-in-one solution.</p>		<p>Easy, one-step install.</p>	
<p>Allows for minimal table height while maintaining necessary stroke length.</p>		<p>Low-cost solution.</p>	
<p>Meets material requirements for medical applications.</p>		<p>Increase productivity and throughput.</p>	
<p>Meets medical 60601 certification requirements.</p>		<p>Reduce workplace injuries.</p>	
<p>Meets audible noise requirements (CE Standards).</p>		<p>Customizable solution.</p>	
<p>Aesthetic design - no need to shroud or cover.</p>		<p>Aesthetic design - no need to shroud or cover.</p>	

# LC2000 - Specifications



## Standard Features and Benefits

- For medical and ergonomic automation applications
- Self-supporting column in extruded anodized aluminum
- Low weight and quiet operation
- Smooth-operating telescopic lead screw drive
- High load torque capability
- Short retracted length
- High extension to retraction ratio
- Maintenance free
- Load holding brake
- Integrated end-of-stroke limit switches
- EMC recognized for medical applications

## General Specifications

Parameter	LC2000
Screw type	telescopic lead screw
Internally restrained	yes
Manual override	no
Dynamic braking	no <sup>(1)</sup>
Holding brake	yes
End-of-stroke protection	end-of-stroke limit switches
Mid-stroke protection	no <sup>(1)</sup>
Motor protection	no <sup>(1)</sup>
Motor connection	cable
Motor connector	Molex 8-pin plug
Certificates	CE EMC for medical applications <sup>(2)</sup>
Options	encoder position feedback
Compatible controls <sup>(3)</sup>	
DCG-180	operation of single unit
DCG-280	synchronous operation of two units

## Performance Specifications

Parameter		LC2000
Maximum load	[N]	2000
Maximum load torque, dynamic / static	[Nm]	150* / 500
Speed, at no load / at maximum load	[mm/s]	19 / 15
Available input voltages	[VDC]	24
Minimum ordering stroke (S)	[mm]	200
Maximum ordering stroke (S)	[mm]	600
Operating temperature limits	[°C]	0 to +40
Full load duty cycle @ 20°C	[%]	15
Maximum on time	[s]	60
Lead cross section	[mm <sup>2</sup> ]	1.5
Standard cable length	[mm]	1900
Protection class		IP44

\* Higher dynamic loads up to 400 Nm available upon request, contact customer support.

## Performance Diagram

Speed and Current vs. Load

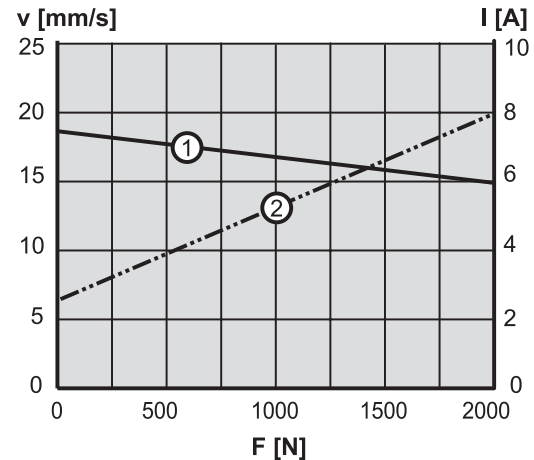

V: speed I: current F: load

1: speed  
2: current

(1) Dynamic braking, mid-stroke protection and motor protection are provided when used with DCG control.

(2) Emission: EN 61000-6-3:2001, EN 60601-1-2:1993, EN 55011 Class B  
Immunity: EN 61000-6-2:2001, EN 61000-4-2, EN 61000-4-3

(3) See page 12 for more information.

# LC2000 - Dimensions and Performance

Dimensions	Projection
METRIC	

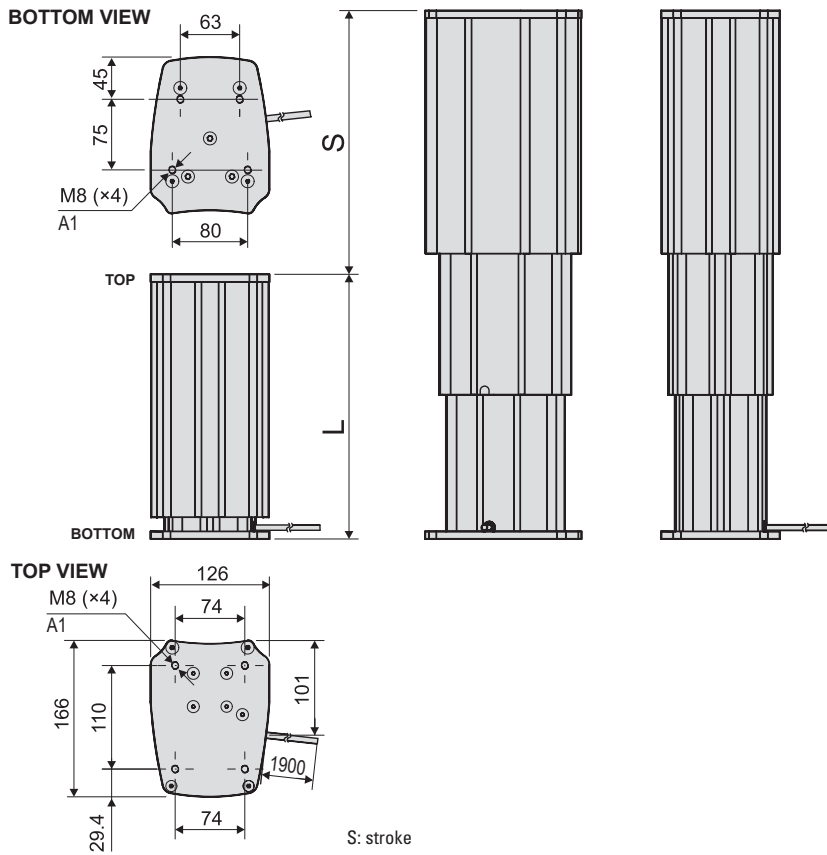

S: stroke  
 L: retracted length  
 A1: mounting screws must not enter deeper than 10 mm.

## Ordering Stroke, Retracted Length and Weight

The desired stroke (S) will determine the minimum retracted length (L min) and the weight of the unit. Units can be built with a retracted length (L) between the calculated L min value and maximum retracted length.

Stroke, retracted length and weight relationship			
		Minimum	Maximum
Stroke (S)	[mm]	200	600
Retracted length (L)	[mm]	250 or L min	441
Min. retracted length (L min) based on stroke (S)	[mm]	$L \text{ min} = (S + 282) / 2$	
Weight of unit based on stroke (S)	[kg]	$\text{Weight} = 3.4 + L [\text{mm}] \times 0.0203 + S [\text{mm}] \times 0.001$	

The table below provides examples of stroke lengths and their corresponding minimum retracted length (L min) values.

Examples of strokes and the resulting minimum retracted length and weight										
Stroke (S)	[mm]	200	250	300	350	400	450	500	550	600
Minimum retracted length (L min)	[mm]	250	266	291	316	341	366	391	416	441
Weight	[kg]	8.7	9.1	9.7	10.2	10.8	11.3	11.9	12.4	13



# LC3000 - Specifications



## Standard Features and Benefits

- For medical and ergonomic automation applications
- Self-supporting column in extruded anodized aluminum
- Low weight and quiet operation
- Smooth-operating ballscrew drive
- High load torque capability
- Short retracted length
- Maintenance free
- Load holding brake
- Integrated end-of-stroke limit switches

## General Specifications

Parameter	LC3000
Screw type	ball screw
Internally restrained	yes
Manual override	no
Dynamic braking	no <sup>(1)</sup>
Holding brake	yes
End-of-stroke protection	end-of-stroke limit switches
Mid-stroke protection	no <sup>(1)</sup>
Motor protection	no <sup>(1)</sup>
Motor connection	cable
Motor connector	Molex 8-pin plug
Certificates	CE
Options	encoder position feedback
Compatible controls <sup>(2)</sup>	DCG-180 DCG-280
	operation of single unit synchronous operation of two units

(1) Dynamic braking, mid-stroke protection and motor protection are provided when used with DCG control.

(2) See page 12 for more information.

## Performance Specifications

Parameter		LC3000
Maximum load	[N]	3000
Maximum load torque, dynamic / static	[Nm]	400 / 500
Speed, at no load / at maximum load	[mm/s]	8 / 6
Available input voltages	[VDC]	24
Minimum ordering stroke (S)	[mm]	200
Maximum ordering stroke (S)	[mm]	400
Operating temperature limits	[°C]	0 to +40
Full load duty cycle @ 20°C	[%]	10
Maximum on time	[s]	60
Lead cross section	[mm <sup>2</sup> ]	1.5
Standard cable length	[mm]	1900
Protection class		IP44

## Performance Diagram

Speed and Current vs. Load

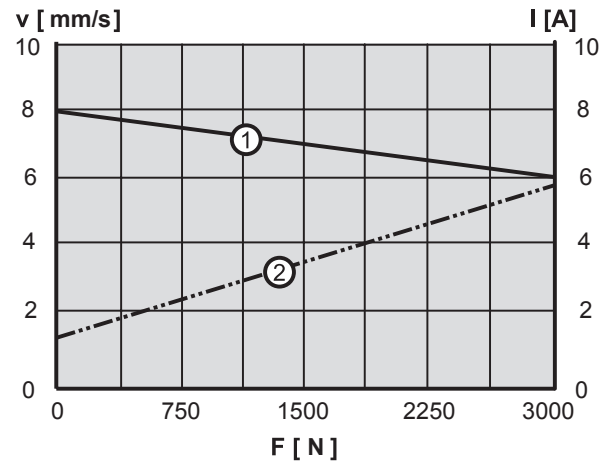

V: speed I: current F: load  
1: speed  
2: current

# LC3000 - Dimensions and Performance

Dimensions	Projection
METRIC	

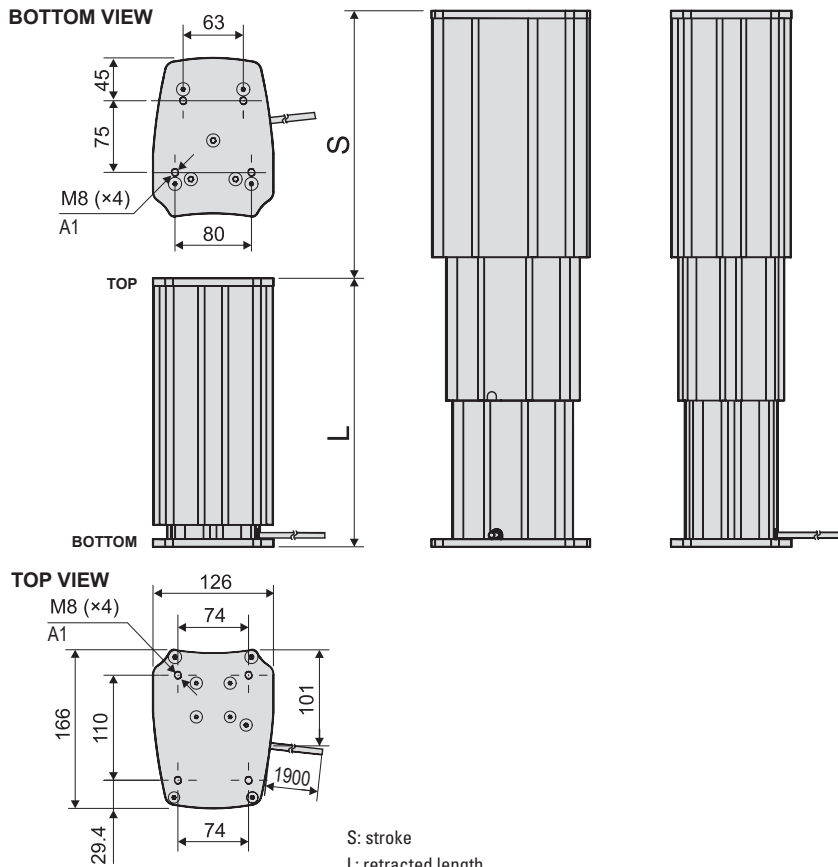

S: stroke  
 L: retracted length  
 A1: mounting screws must not enter deeper than 10 mm.

## Ordering Stroke, Retracted Length and Weight

The desired stroke (S) will determine the minimum retracted length (L min) and the weight of the unit. Units can be built with a retracted length (L) between the calculated L min value and maximum retracted length.

Stroke, retracted length and weight relationship		
	Minimum	Maximum
Stroke (S) [mm]	200	400
Retracted length (L) [mm]	330 or L min	530
Min. retracted length (L min) based on stroke (S) [mm]	$L \text{ min} = S + 130$	
Weight of unit based on stroke (S) [kg]	$\text{Weight} = 4.065 + ((0.01774 \times L \text{ [mm]}) - 0.6031) + (S \text{ [mm]} + 70) \times 0.0012$	

The table below provides examples of stroke lengths and their corresponding minimum retracted length (L min) values.

Examples of strokes and the resulting minimum retracted length and weight						
Stroke (S) [mm]	200	250	300	350	400	
Minimum retracted length (L min) [mm]	330	380	430	480	530	
Weight [kg]	9.7	10.6	11.6	12.5	13.5	

# Wiring Diagrams

## LC2000 and LC3000

### Standard (NX) or with encoder feedback option (NE)

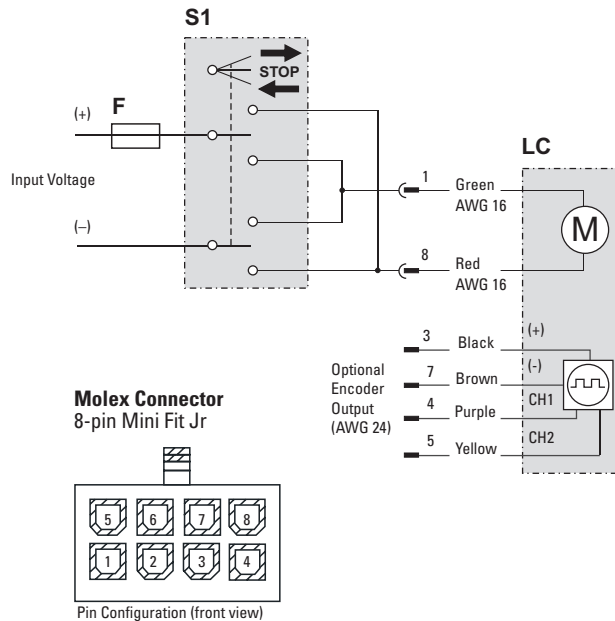

- LC Lifting column
- M Lifting column motor
- E Electronic limit switches
- S1 Double-pole double throw (DPDT) switch (provided by the customer)
- S2 Single-pole double throw (SPDT) switch
- F Fuse (provided by the customer)

Connect the green lead (pin 1) to positive and the red (pin 8) to negative to extend the lifting column. Change polarity to retract the lifting column.

LC2000 and LC3000 are provided with internal limit switches. No external wiring is required for these switches.

The encoder version (NE) is optional and would be used when feedback is required or when synchronization of multiple units is necessary. If in use it should be supplied with 5 - 18 Vdc on black (pin 3) and brown (pin 7) leads, and the two encoder channels are generated on purple (pin 4) and yellow (pin 5).

Encoder Option Data	
Supply Voltage	5-18 VDC
Pulses per mm/stroke	6.62
Output Type	Open collector
Output Current	I <sub>source</sub> ≤ 400 uA; I <sub>sink</sub> ≤ 2 mA
Output Voltage	U <sub>out</sub> : ≥ U <sub>supply</sub> x 0.7; U <sub>out</sub> : ≤ 1.5 V

## Ordering Keys

LC2000 Ordering Key					
Position	1	2	3	4	5
Example	<b>LC2000</b>	<b>N</b>	<b>24</b>	<b>-400341</b>	<b>NX</b>
1. Lifting column model LC2000 = LC2000  2. Type N = standard		3. Supply voltage 24 = 24 VDC  4. Stroke and retracted length -400341 = 400 and 341 mm <sup>(1)</sup>		5. Connection and encoder options NE = Cable (L = 1900 mm), Molex connector, encoder feedback <sup>(2)</sup> NX = Cable (L = 1900 mm), Molex connector, no encoder feedback  (1) This is just an example, see section Ordering Stroke, Retracted Length and Weight on page 7 for directions on how to calculate this number. (2) Encoders are used when synchronizing multiple units.	

LC3000 Ordering Key					
Position	1	2	3	4	5
Example	<b>LC3000</b>	<b>N</b>	<b>24</b>	<b>-400530</b>	<b>NX</b>
1. Lifting column model LC3000 = LC3000  2. Type N = standard		3. Supply voltage 24 = 24 VDC  4. Stroke and retracted length -400530 = 400 and 530 mm <sup>(1)</sup>		5. Connection and encoder options NE = Cable (L = 1900 mm), Molex connector, encoder feedback <sup>(2)</sup> NX = Cable (L = 1900 mm), Molex connector, no encoder feedback  (1) This is just an example, see section Ordering Stroke, Retracted Length and Weight on page 9 for directions on how to calculate this number. (2) Encoders are used when synchronizing multiple units.	

# DCG Control Series

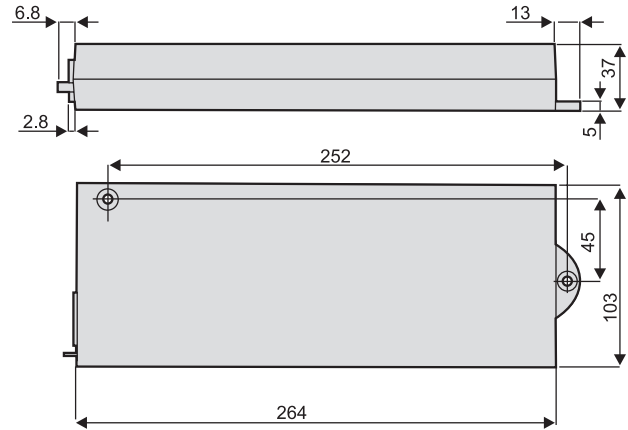

### Standard Features and Benefits

- Controls available for single lifting column operation or synchronous operation of two lifting columns equipped with encoders
- Small and lightweight control operated via a control pendant (ordered separately)
- Built-in electronic limit switches (ELS) stop the lifting column automatically at end of stroke or mid-stroke stall
- No wiring is necessary to the control as all connections are done through plugs

### Compatibility

Control	Lifting Column
DCG-180	Single operation of one LC2000 or LC3000 <sup>(1)</sup>
DCG-280	Synchronous operation of two LC2000 or LC3000 <sup>(2)(3)</sup>
DCG-280C	Synchronous operation of four LC2000 or LC3000 <sup>(2)(3)</sup>

(1) The lifting column should be equipped with the no encoder (NX) option.

(2) Lifting columns used in synchronous operation must be equipped with encoder (NE) option.

(3) Synchronous operation of six units is also available. Contact Thomson customer support for details.

### Performance Specifications

Parameter	DCG-180	DCG-280	DCG-280C
Input voltage [VAC]	1 × 230 ± 6% or 1 × 115 ± 6%		
Input frequency [Hz]	50/60		
Output voltage [VDC]	24		
Output current, max. up/down [A]	8	2 × 8	4 × 8
Operating temperature limits [°C]	+0 to +30		
Max. duty cycle @ 25°C <sup>(1)</sup> [%]	10		
Maximum on time [s]	60		
Weight of control [kg]	0.5		
Protection class	Class 1 (not for outdoor use)		
Electronic limit switches	yes <sup>(2)</sup>		
Included control pendant	no		
Certificates	CE		

(1) Control will shut off if duty cycle is exceeded and automatically reset when cooled off.

(2) DCG-280 monitors the encoder pulses and not the motor currents. If the pulses arrives too slowly or not at all it will stop the motion of both lifting columns.

# DCG Control Pendant

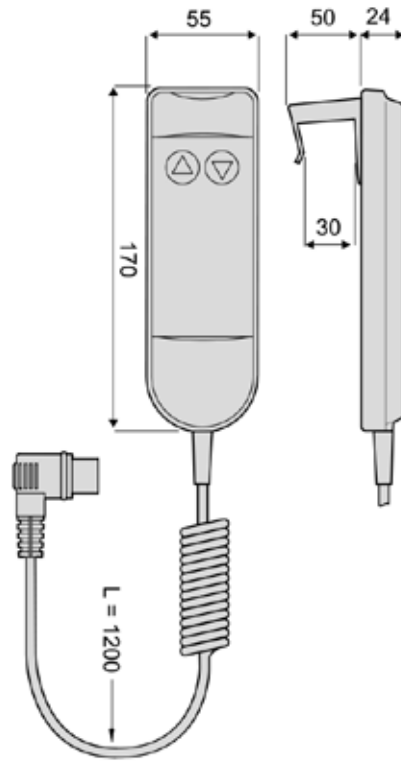

### Standard Features and Benefits

- Handy and lightweight control pendant
- 1.2-meter-long spiral cord cable
- Connects to the DCG control with a plug

### Specifications

Parameter	DCG14-1H	
Weight	[kg]	0.4
Cable length	[mm]	1200
Certificates	CE	
Part number	DCG14-1H	

### DCG Actuator Controls Ordering Key

1	2	3	4	5
<b>DGC</b>	<b>24</b>	<b>-1</b>	<b>M</b>	<b>-0180</b>

<p>1. Type of control DCG = actuator control type DCG</p> <p>2. Output voltage 24 = 24 VDC</p> <p>3. Type of operation -1 = operation of a single actuator -2 = operation of two parallel synchronous actuators -4 = operation of four parallel synchronous actuators</p>	<p>4. Input voltage M = 230 Vac U = 115 Vac</p> <p>5. Matching actuator -0180 = single drive of LC2000, LC3000 -0280 = parallel synchronous drive of two LC2000 or LC3000 actuators with encoder feedback -0280C = parallel synchronous drive of four LC2000 or LC3000 actuators with encoder feedback</p>
---	--



– Page intentionally left blank –

– Page intentionally left blank –

Contact us or any of our 2000+ global distribution partners by scanning the code below  
or visiting [www.thomsonlinear.com/contact](http://www.thomsonlinear.com/contact)



**RegalRexnord™**

[www.regalrexnord.com](http://www.regalrexnord.com)

[www.thomsonlinear.com](http://www.thomsonlinear.com)

Lifting\_Columns\_BREN-0007-05 | 20260217SK | MCB-12396-TL-EN-US 02/26  
Specifications are subject to change without notice. It is the responsibility of the product user to determine the suitability of this product for a specific application. All trademarks property of their respective owners. ©2026 Thomson Industries, Inc. | 2400 Curtiss Street, Downers Grove, IL 60515 USA

**THOMSON®**