



Polymer Bushing Bearings

Reliable, Corrosion-Resistant Linear Motion Solution for
Low-Load, Low-Speed Applications



Increase Your Motion System Design Flexibility

Thomson polymer bushing bearings offer linear motion designers a reliable, yet economical, option for machines in which moment load is non-critical or where contamination and temperature are concerns. These bearings are also useful for applications that require shafting that is incompatible with Thomson Ball Bushing® Bearings such as aluminum or 316 stainless steel.

A Reliable and Versatile Alternative

Handling loads up to 9000 N (2023 lbf), polymer bushing bearings provide a corrosion-resistant option for low-load, low-speed applications. When combined with round rail shafting, pillow blocks or other assembly components, polymer bushing bearings deliver a budget-friendly linear motion solution to a number of applications.

Polymer Bushing Bearings Applications

- Factory Automation
- Robotics
- Health and Fitness
- Medical Automation
- Woodworking
- Packaging
- Food and Beverage
- Vending

Polymer Bushing Bearings Highlights

- Available in sizes of 6 to 50 mm (closed) and 10 to 50 mm (open)
- Maintenance-free operation
- Polymer liners reduce noise
- Dirt and dust resistant
- Anodized aluminum adapter
- Available with aluminum pillow blocks
- Operate in temperatures ranging from - 50°C to 90°C (- 58°F to 194°F)
- Available in open and closed types

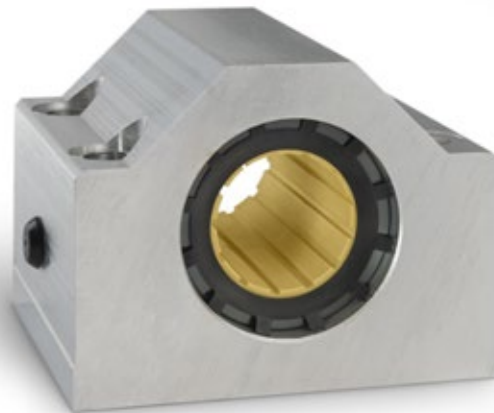

Speed vs. Load

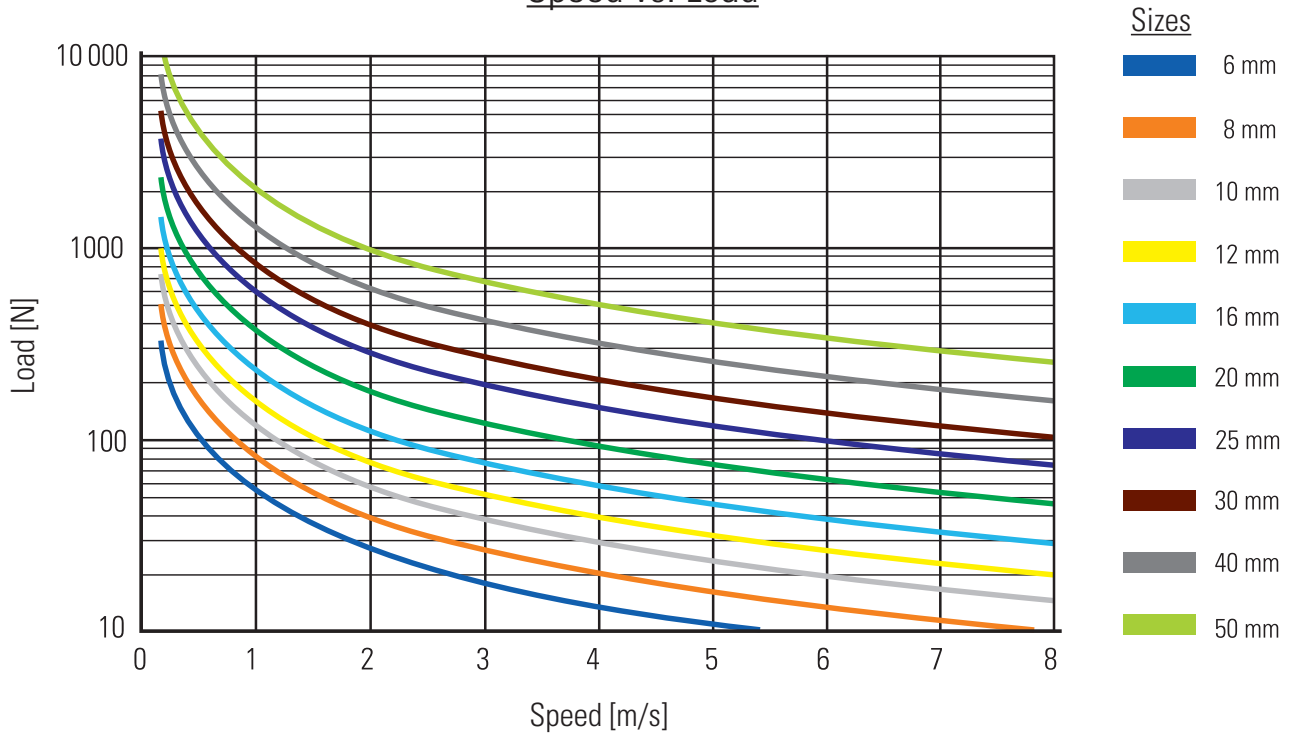

Technical Specifications

Max. load	[N (lbf)]	9000 (2023)
Max. speed	[m/s (in/sec)]	8 (315)
Bushing sizes closed type	[mm]	6, 8, 10, 12, 16, 20, 25, 30, 40, 50
Bushing sizes open type	[mm]	10, 12, 16, 20, 25, 30, 40, 50
Operating temperature limits	[°C (°F)]	- 50 – 90 (- 58 – 194)
Housing material		anodized aluminum
Pillow block material		aluminum

Ordering Key

1	2	3
PL	M08	OPN
1. Type PL = Polymer Bushing PLB = Polymer bushing pillow block PLTB = Polymer bushing twin pillow block	2. Size M08 = 8mm M10 = 10mm M12 = 12mm M16 = 16mm M20 = 20mm M25 = 25mm M30 = 30mm M40 = 40mm M50 = 50mm	3. Configuration (blank) = Closed OPN = Open



Polymer Bushings - Closed Type

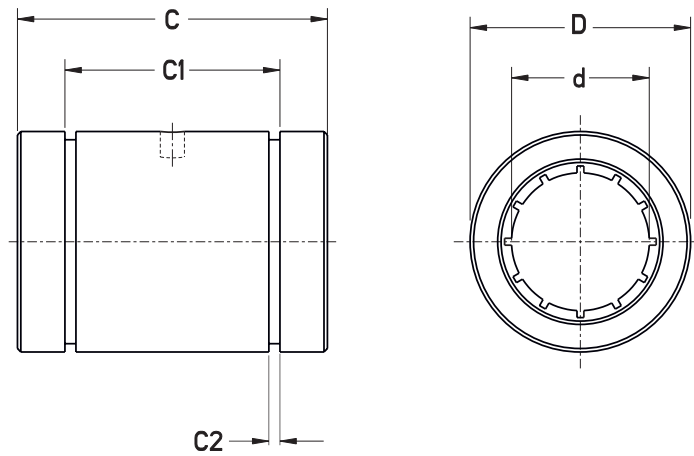

Dimensions	Projection
mm	

Dimensions [mm]

Part Number	Inside Diameter (d)	Inside Diameter Tolerance	Outside Diameter (D)	Length (C)	Retaining Rings Distance (C1)	Retaining Rings Groove Width (C2)
PLM06	6	+0.020/+0.068	12	22	14.2	1.1
PLM08	8	+0.025/+0.083	16	25	16.2	1.1
PLM10	10	+0.030/+0.088	19	29	21.6	1.3
PLM12	12	+0.030/+0.088	22	32	22.6	1.3
PLM16	16	+0.030/+0.088	26	36	24.6	1.3
PLM20	20	+0.030/+0.091	32	45	31.2	1.6
PLM25	25	+0.030/+0.091	40	58	43.7	1.85
PLM30	30	+0.040/+0.110	47	68	51.7	1.85
PLM40	40	+0.040/+0.115	62	80	60.3	2.15
PLM50	50	+0.050/+0.0130	75	100	77.3	2.65

Part Number	Shaft Diameter	Dynamic Load F max. (N) P = 5 MPa	Static Load F max. (N) P = 35 MPa	Weight [kg]
PLM06	6	525	3675	5
PLM08	8	960	6720	9
PLM10	10	725	5075	12
PLM12	12	960	6720	20
PLM16	16	1440	10080	28
PLM20	20	2250	15750	50
PLM25	25	3625	25375	104
PLM30	30	5100	35700	163
PLM40	40	8000	56000	341
PLM50	50	9000	87500	589

Polymer Bushings - Open Type

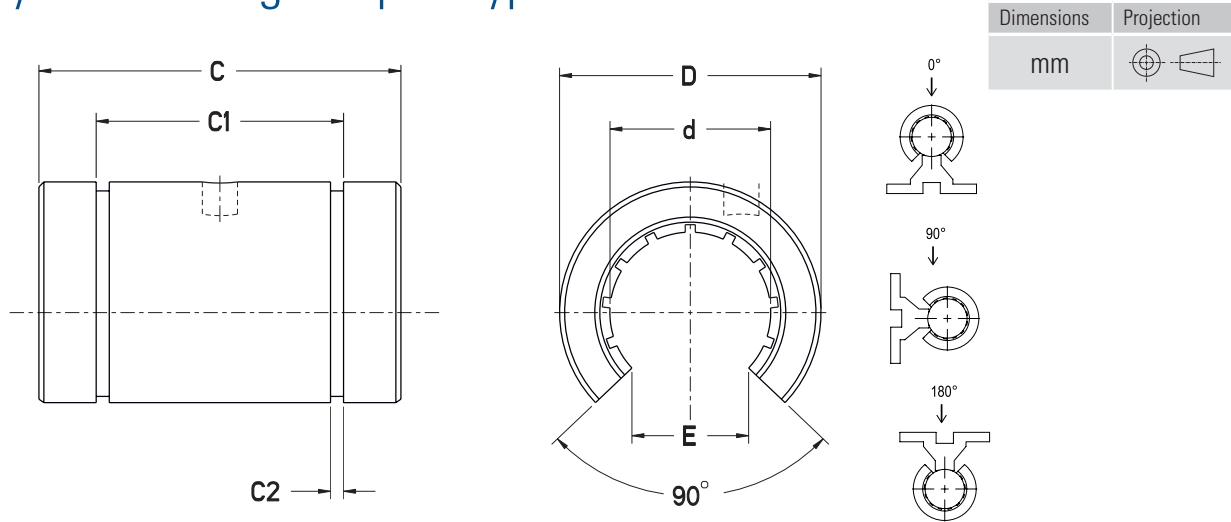

Dimensions [mm]

Part Number	Inside Diameter (d)	Inside Diameter Tolerance	Outside Diameter (D)	Length (C)	Retaining Rings Distance (C1)	Retaining Rings Groove Width (C2)	Opening Width (E)
PLM100PN	10	+0.030/+0.088	19	29	21.6	1.30	7.3
PLM120PN	12	+0.030/+0.088	22	32	22.6	1.30	9.0
PLM160PN	16	+0.030/+0.088	26	36	24.6	1.30	11.6
PLM200PN	20	+0.030/+0.091	32	45	31.2	1.60	12.0
PLM250PN	25	+0.030/+0.091	40	58	43.7	1.85	14.5
PLM300PN	30	+0.040/+0.110	47	68	51.7	1.85	16.6
PLM400PN	40	+0.040/+0.115	62	80	60.3	2.15	21.0
PLM500PN	50	+0.050/+0.130	75	100	77.3	2.65	25.5

Part Number	Shaft Diameter	Dynamic Load F max. (N) P = 5 MPa			Static Load F max. (N) P = 35 MPa			Weight [kg]
		0°	90°	180°	0°	90°	180°	
PLM100PN	10	725	500	196	5075	3500	1370	9
PLM120PN	12	960	635	240	6720	4445	1680	15
PLM160PN	16	1440	990	396	10080	6943	2772	21
PLM200PN	20	2250	1800	900	15750	12600	6300	37
PLM250PN	25	3625	2953	1523	25375	20670	10658	78
PLM300PN	30	5100	4250	2278	35700	29735	15948	122
PLM400PN	40	8000	6810	3800	56000	47660	26600	256
PLM500PN	50	12500	10750	6125	87500	75265	42875	442



Pillow Blocks - Closed Type

Single Block / Twin Block

Dimensions	Projection
mm	

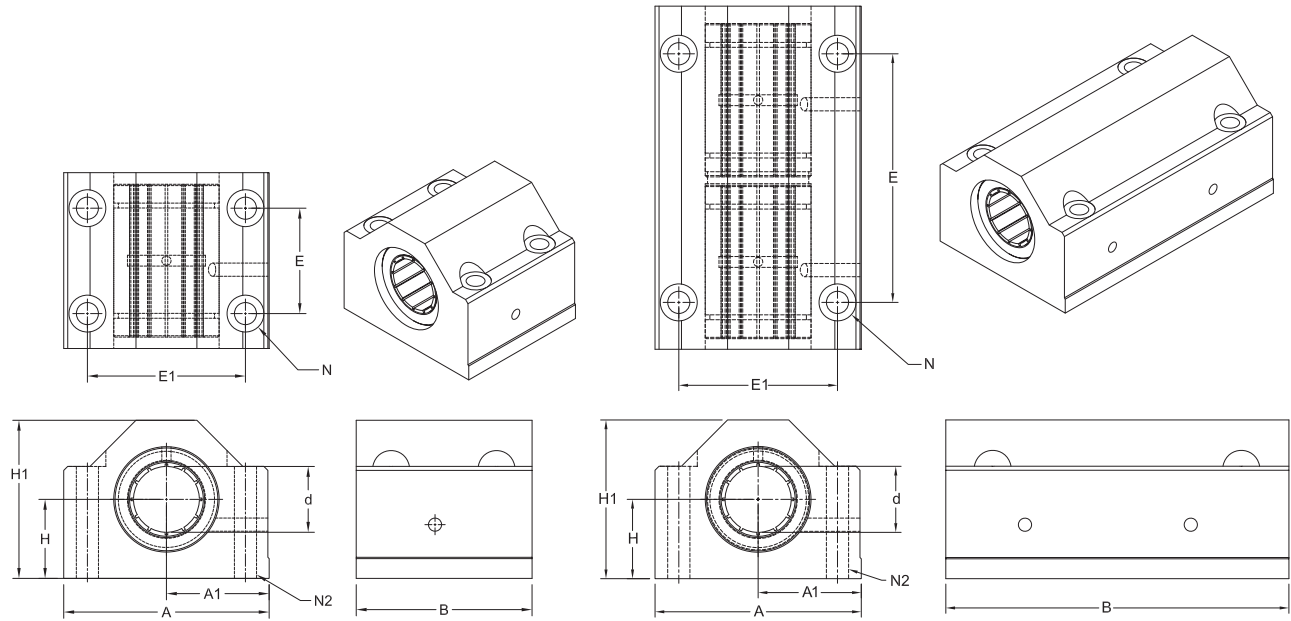

Single Block Dimensions [mm]

Part Number	Inside Diam. (d)	Center Height ± 0.02 (H)	Block Height (H1)	Block Width (A)	Center Width ± 0.02 (A1)	Block Length (B)	Hole Length ± 0.1 (E)	Hole Width ± 0.1 (E1)	Hole Diam. (N)	Thread Size \times Length (N2)	Weight [kg]
PLBM12	12	18	35	43	21.5	39	23	32	4.3	M5 \times 11	0.117
PLBM16	16	22	42	53	26.5	43	26	40	5.3	M6 \times 13	0.180
PLBM20	20	25	50	60	30.0	54	32	45	6.6	M8 \times 18	0.300
PLBM25	25	30	60	78	39.0	67	40	60	8.4	M10 \times 22	0.571
PLBM30	30	35	71	87	43.5	79	45	68	8.4	M10 \times 22	0.889
PLBM40	40	45	91	108	54.0	91	58	86	10.5	M12 \times 26	1.638

Twin Block Dimensions [mm]

Part Number	Inside Diam. (d)	Center Height ± 0.02 (H)	Block Height (H1)	Block Width (A)	Center Width ± 0.02 (A1)	Block Length (B)	Hole Length ± 0.1 (E)	Hole Width ± 0.1 (E1)	Hole Diam. (N)	Thread Size \times Length (N2)	Weight [kg]	Dynamic Load [N]	Static Load [N]
PLTBM12	12	18	35	43	21.5	75	56	32	4.3	M5 \times 11	0.232	1920	13440
PLTBM16	16	22	42	53	26.5	84	64	40	5.3	M6 \times 13	0.361	2880	20160
PLTBM20	20	25	50	60	30.0	104	76	45	6.6	M8 \times 18	0.608	4500	31500
PLTBM25	25	30	60	78	39.0	130	94	60	8.4	M10 \times 22	1.143	7250	50750
PLTBM30	30	35	71	87	43.5	152	106	68	8.4	M10 \times 22	1.757	10200	71400
PLTBM40	40	45	91	108	54.0	176	124	86	10.5	M12 \times 26	3.256	16000	112000

Pillow Blocks - Open Type

Single Block / Twin Block

Dimensions	Projection
mm	

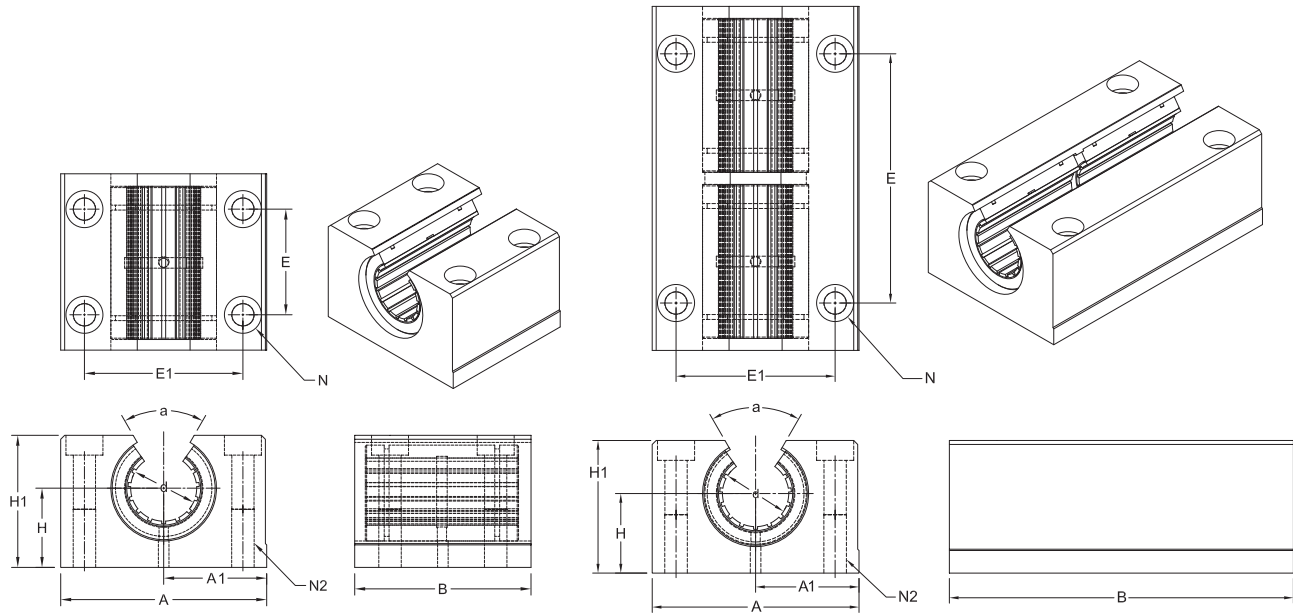

Single Block Dimensions [mm]

Part Number	Inside Diam. (d)	Center Height ± 0.02 (H)	Block Height (H1)	Block Width (A)	Center Width ± 0.02 (A1)	Block Length (B)	Hole Length ± 0.1 (E)	Hole Width ± 0.1 (E1)	Hole Diam. (N)	Thread Size \times Length (N2)	Opening Angle (a) [°]	Weight [kg]
PLBM12PN	12	18	28	43	21.5	39	23	32	4.3	M5 \times 11	66	0.097
PLBM16PN	16	22	35	53	26.5	43	26	40	5.3	M6 \times 13	70	0.159
PLBM20PN	20	25	42	60	30.0	54	32	45	6.6	M8 \times 18	50	0.253
PLBM25PN	25	30	51	78	39.0	67	40	60	8.4	M10 \times 22	60	0.507
PLBM30PN	30	35	60	87	43.5	79	45	68	8.4	M10 \times 22	55	0.797
PLBM40PN	40	45	77	108	54.0	91	58	86	10.5	M12 \times 26	54	1.435

Twin Block Dimensions [mm]

Part Number	Inside Diam. (d)	Center Height ± 0.02 (H)	Block Height (H1)	Block Width (A)	Center Width ± 0.02 (A1)	Block Length (B)	Hole Length ± 0.1 (E)	Hole Width ± 0.1 (E1)	Hole Diam. (N)	Thread Size \times Length (N2)	Opening Angle (a) [°]	Weight [kg]
PLTBM12PN	12	18	28	43	21.5	76	56	32	4.3	M5 \times 11	66	0.197
PLTBM16PN	16	22	35	53	26.5	84	64	40	5.3	M6 \times 13	70	0.323
PLTBM20PN	20	25	42	60	30.0	104	76	45	6.6	M8 \times 18	50	0.508
PLTBM25PN	25	30	51	78	39.0	130	94	60	8.4	M10 \times 22	60	1.028
PLTBM30PN	30	35	60	87	43.5	152	106	68	8.4	M10 \times 22	55	1.588
PLTBM40PN	40	45	77	108	54.0	176	124	86	10.5	M12 \times 26	54	2.879

Contact us or any of our 2000+ global distribution partners by scanning the code below
or visiting www.thomsonlinear.com/contact



RegalRexnord™

www.regalrexnord.com

www.thomsonlinear.com

Polymer_Bushing_Bearings_BREN-0036-03 | 20260226TJ | MCB-12407-TL-EN-US 02/26
Specifications are subject to change without notice. It is the responsibility of the product user to determine
the suitability of this product for a specific application. All trademarks property of their respective owners.
©2026 Thomson Industries, Inc. | 2400 Curtiss Street, Downers Grove, IL 60515 USA

THOMSON®